



★ ★ ★ ★ ★ ★ **HELLO KITTY** ★ ★ ★ ★ ★ ★
©1976, 2013 SANRIO CO., LTD.

CD Boombox with AM/FM Stereo Radio





USER MANUAL
KT2026MBY

CAUTION: Electrically Operated Product – Please use care when plugging into AC outlet.

WARNING

TO PREVENT FIRE OR SHOCK HAZARD, DO NOT USE THIS PLUG WITH AN EXTENSION CORD, RECEPTACLE OR OTHER OUTLET UNLESS THE BLADES CAN BE FULLY INSERTED TO PREVENT BLADE EXPOSURE. TO PREVENT FIRE OR SHOCK HAZARD, DO NOT EXPOSE THIS APPLIANCE TO RAIN OR MOISTURE.

 <p>The lightning flash and arrow head within the triangle is a warning sign alerting you of "dangerous voltage" inside the product.</p>	<p>CAUTION RISK OF ELECTRIC SHOCK DO NOT OPEN</p> <p>CAUTION: TO REDUCE THE RISK OF ELECTRIC SHOCK DO NOT REMOVE COVER (ON BACK), NO USER SERVICEABLE PARTS INSIDE. REFER SERVICING TO QUALIFIED SERVICE PERSONNEL.</p>	 <p>The exclamation point within the triangle is a warning sign alerting you of important instructions accompanying the product.</p>
---	--	---

Caution Marking located at bottom enclosure of the apparatus

IMPORTANT SAFETY INSTRUCTIONS

1. Read these instructions.
2. Keep these instructions.
3. Heed all warnings.
4. Follow all instructions.
5. Do not use this apparatus near water.
6. Cleaning – Unplug this product from the wall outlet before cleaning. Do not use liquid cleaners or aerosol cleaners. Clean only with a dry cloth.
7. Do not block any ventilation openings. Install in accordance with the manufacturer's instructions.
8. Do not install near any heat sources such as radiators, heat registers, stoves, or other apparatus (including amplifiers) that produce heat.
9. Do not defeat the safety purpose of the polarized or grounding-type plug. A polarized plug has two blades with one wider than the other. A grounding type plug has two blades and a third grounding prong. The wider or the third prong is provided for your safety. If the provided plug does not fit into your outlet, consult an electrician for replacement of the obsolete outlet.
10. Protect the power cord from being walked on or pinched particularly at plugs, convenience receptacles, and the point where they exit from the apparatus.
11. Only use attachments/accessories specified by the manufacturer.
12. Use only with a cart, stand, tripod, bracket, or table specified by the manufacturer, or sold with the apparatus. When a cart is used, use caution when moving the cart/ apparatus combination to avoid injury from tip-over.
13. Unplug this apparatus during lightning storms or when unused for long periods of time.
14. Refer all servicing to qualified service personnel. Servicing is required when the apparatus has been damaged in any way, such as power supply cord or plug is damaged, liquid has



- been spilled or objects have fallen into the apparatus, the apparatus has been exposed to rain or moisture, does not operate normally, or has been dropped.
15. This apparatus shall not be exposed to dripping or splashing water and that no object filled with liquids such as vases shall be placed on the apparatus.
 16. Main plug is used as disconnect device and it should remain readily operable during intended use. In order to disconnect the apparatus completely, the main plug should be disconnected from the main socket outlet completely.
 17. Battery shall not be exposed to excessive heat such as sunshine, fire or the like.
 18. The marking information is located at the bottom of the apparatus.
 19. The Caution Marking is located at the bottom of the apparatus.
 20. Danger of explosion if battery is incorrectly replaced. Replace only with the same or equivalent type.

This symbol indicates that this product incorporates double insulation between hazardous mains voltage and user accessible parts



**CAUTION:
TO PREVENT ELECTRIC SHOCK, MATCH
WIDE BLADE OF AC PLUG TO WIDE SLOT.
FULLY INSERT.**

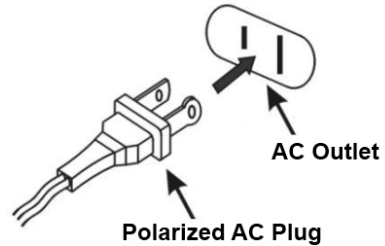

SAVE THESE INSTRUCTIONS

CAUTION

CLASS 1 LASER PRODUCT

CLASS 1 LASER PRODUCT
APPAREIL À LASER DE CLASSE 1
PRODUCTO LÁSER DE CLASE 1

CAUTION
INVISIBLE LASER RADIATION
WHEN OPEN AND INTERLOCKS
DEFEATED.
AVOID EXPOSURE TO BEAM.



This product contains a low power laser device.

Follow the advice below for safe operations.

ON PROTECTION AGAINST LASER ENERGY EXPOSURE

- As the laser beam used in this compact disc player is harmful to the eyes, do not attempt to disassemble the casing.
- Stop operation immediately if any liquid or solid object should fall into the cabinet.

- Do not touch the lens or poke at it. If you do, you may damage the lens and the player may not operate properly.
- Do not put anything in the safety slot. If you do, the laser diode will be “ON” when the CD door is still open.
- If the unit is not to be used for a long period of time, make sure that all power sources are disconnected from the unit. Remove all batteries from the battery compartment, and unplug the AC cord from the wall outlet. Make it a practice to remove the AC cord by grasping the main body and not by pulling the cord.
- This unit employs a laser. The use of controls or adjustment or performance of procedures other than those specified here may result in exposure to hazardous radiation.

ON PLACEMENT

- Do not use the unit in places which are extremely hot, cold, dusty or humid.
- Place the unit on a flat and even surface.
- Do not restrict the air-flow of the unit by placing it in a place with poor ventilation, by covering it with a cloth or by placing it on a carpet.

ON CONDENSATION

- When left in a heated room where it is warm and damp, water droplets or condensation may form inside the unit.
- When there is condensation inside the unit, the unit may not function normally.
- Let it stand for 1 to 2 hours before turning the power on, or gradually heat the room up and dry the unit before use.

Should any trouble occur, remove the power source and refer servicing to qualified personnel.

COMPLIANCE WITH FCC REGULATIONS

This device complies with Part 15 of the FCC Rules. Operation is subject to the following two conditions:

- (1) this device may not cause harmful interference, and
- (2) this device must accept any interference received, including interference that may cause undesired operation.

NOTE : This equipment has been tested and found to comply with the limits for a Class B digital device, pursuant to Part 15 of the FCC Rules. These limits are designed to provide reasonable protection against harmful interference in a residential installation. This equipment generates, uses and can radiate radio frequency energy and, if not installed and used in accordance with the instructions, may cause harmful interference to radio communications. However, there is no guarantee that interference will not occur in a particular installation. If this equipment does cause harmful interference to radio or television reception, which can be determined by turning the equipment off and on, the user is encouraged to try to correct the interference by one or more of the following measures:

- Reorient or relocate the receiving antenna.
- Increase the separation between the equipment and receiver.
- Connect the equipment into an outlet on a circuit different from that to which the receiver is connected.
- Consult the dealer or an experienced radio/TV technician for help.

CAUTION: Changes or modifications not expressly approved by the party responsible for compliance could void the user's authority to operate the equipment.

PROTECT YOUR FURNITURE!!

This system is equipped with non-skid rubber 'feet' to prevent the product from moving when you operate the controls. These 'feet' are made from non-migrating rubber material specially formulated to avoid leaving any marks or stains on your furniture. However certain types of oil based furniture polishes, wood preservatives, or cleaning sprays may cause the rubber 'feet' to soften, and leave marks or a rubber residue on the furniture.

To prevent any damage to your furniture we strongly recommend that you purchase small self-adhesive felt pads, available at hardware stores and home improvement centers everywhere, and apply these pads to the bottom of the rubber 'feet' before you place the product on fine wooden furniture.

LOCATION OF CONTROLS

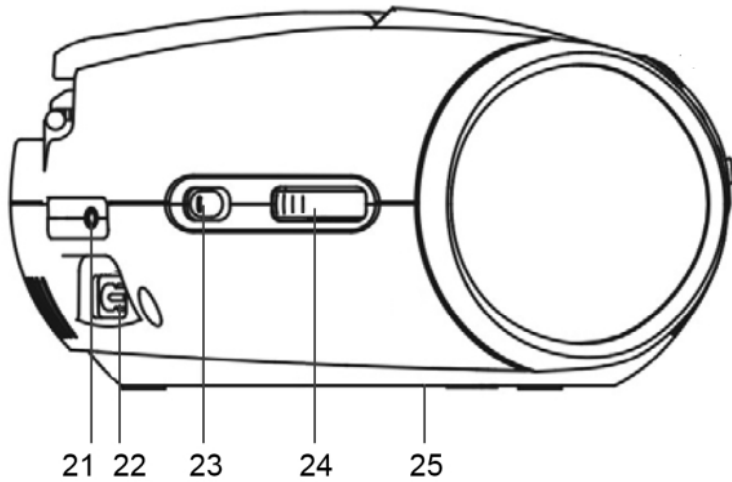
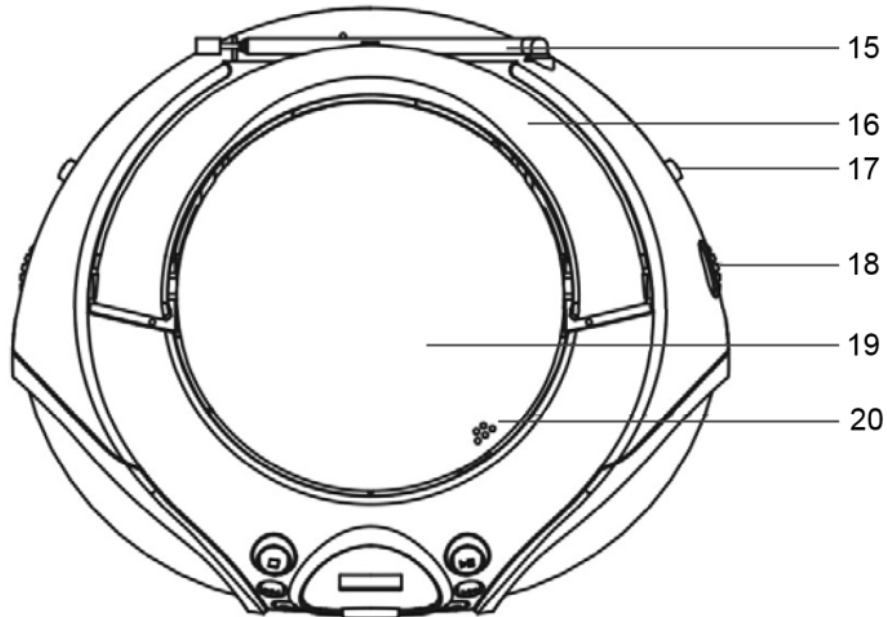
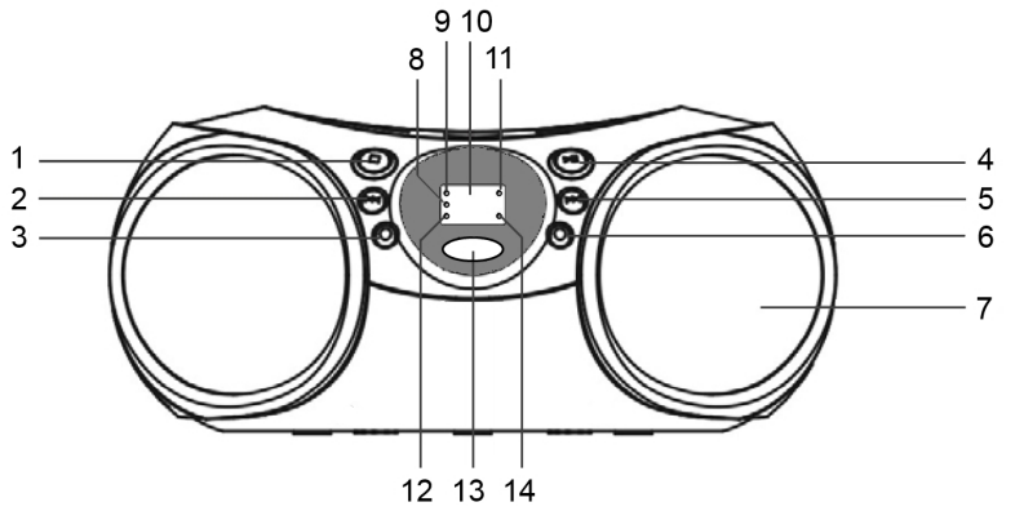

1. Stop Button	14. PLAY/PAUSE Indicator
2. Back/Search Backward ◀◀ Button	15. Telescopic Antenna
3. Program Button	16. Foldable Handle
4. Play/Pause Button	17. Band Selector (AM/FM Stereo)
5. Next/Search Forward ▶▶ Button	18. Tuning Control
6. Random Button	19. CD Compartment Cover
7. Speakers	20. CD Door Open/Close
8. REPEAT Indicator	21. AUX IN Jack
9. POWER Indicator	22. AC Power Socket
10. LED Display	23. Function Selector (CD/AUX/OFF/RADIO)
11. FM Stereo Indicator	24. Volume Control
12. PROGRAM (PROG) Indicator	25. Battery Compartment Cover
13. Repeat Button	

POWER SOURCES

This unit operates on AC 120V~ 60Hz or 6 pieces of DC1.5V “C” (UM-2) batteries. Do not attempt to operate the radio on any other power source. You could cause damage to the unit and void your warranty.

Please be sure the power outlet you plug this unit into is working and receives constant power.

A. BATTERY OPERATION

1. Remove the BATTERY COMPARTMENT COVER.
2. Following the polarity diagram as shown inside the battery compartment insert 6 x ‘C’ (UM-2) batteries (not included) then replace the BATTERY COMPARTMENT COVER.

IMPORTANT: Be sure that the batteries are installed correctly. Wrong polarity may damage the unit.

3. Use only the size and type of batteries specified.
4. For better performance and longer operating time, we recommend alkaline-type batteries.
5. Do not mix old and new batteries.
6. Do not mix alkaline, standard (carbon-zinc) or rechargeable (nickel-cadmium) batteries.
7. If the unit is not to be used for an extended period of time, remove the batteries. Old or leaking batteries can cause damage to the unit and may void the warranty.
8. Do not try to recharge batteries not intended to be recharged; they can overheat and rupture. (Follow battery manufacturer’s directions).
9. Do not dispose of batteries in fire, batteries may leak or explode.

BATTERY REPLACEMENT

When the output sound of this unit becomes distorted or the CD player operation appears unstable, the batteries are weak. You need to replace all the exhausted batteries at the same time as soon as possible to avoid battery leakage.

B. AC OPERATION

When the plug of the provided AC POWER CORD is plugged into to a wall outlet with AC 120V~ 60Hz power supply, the unit will disconnect the batteries automatically, and operate from AC power instead.

IMPORTANT:

This unit has a polarized AC plug with one wide blade and one narrow blade. This plug will only fit into a matching polarized AC outlet. This is a safety feature to reduce the possibility of electric shock. If this plug will not fit in your AC outlet, you probably have an outdated non-polarized outlet. You should have your outdated outlet changed by a qualified, licensed electrician. Do not file the wide blade on the plug, or use an adapter to make the plug fit onto your outlet. This defeats the safety feature and could expose you to electric shock.

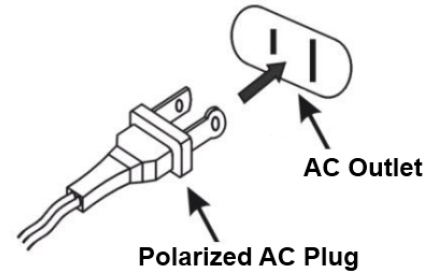

RADIO OPERATION

1. Slide the FUNCTION SELECTOR to "RADIO". The POWER INDICATOR will light.
2. Rotate the TUNING CONTROL to your desired radio station according to the DIAL SCALE.
3. Rotate the VOLUME CONTROL to adjust to the desired output level.
4. To turn off the radio, slide the FUNCTION SWITCH to "OFF".

TIPS FOR BEST RECEPTION

AM – The AM antenna is located inside the cabinet of the unit. If AM reception is weak, change the position of unit until the internal antenna picks up the strongest signal.

FM – If a stereo broadcast program is being received, the FM STEREO INDICATOR will light. During FM reception, always keep the TELESCOPIC ANTENNA fully extended for best performance. However, if FM reception is weak, try repositioning the unit near an open window until you get the best reception.

CD OPERATION

THIS UNIT NOT ONLY PLAYS COMMERCIAL COMPACT DISCS BUT ALSO SELF-COMPILED CD-RW DISCS.

- Because of non-standardized format definition/production of CD-R/RW, playback quality & performance is not guaranteed.
- Manufacturer is not responsible for the playability of CD-R/RW due to recording conditions such as PC performance, writing software, media properties etc.
- Do not attach a label or seal to either side of the CD-R/RW disc. It may cause a malfunction.

PLAY MODE

1. Slide the FUNCTION SELECTOR to the "CD/AUX" position. The POWER INDICATOR will light.
2. Open the CD COMPARTMENT COVER, the LED DISPLAY will show "00". Load a CD with the label side facing upward and then close it.
3. A few seconds later the total number of tracks on the CD will appear on the LED display.
4. Press the PLAY/PAUSE BUTTON to start playing the CD from the first track. The PLAY/PAUSE INDICATOR will light steadily.
5. Adjust the volume control to the desired volume level.
6. While playing, press the PLAY/PAUSE BUTTON once to pause, the PLAY/PAUSE INDICATOR will flash. Press PLAY/PAUSE BUTTON again to resume playing.

7. Press STOP BUTTON to stop playing.
8. To turn off the CD player, slide the FUNCTION SELECTOR to "OFF". The LED DISPLAY and POWER INDICATOR will go off.

Note: Never open the CD DOOR when a CD is playing to avoid possible exposure to laser radiation.

REPEAT MODE

Repeat 1

When the REPEAT BUTTON is pressed once, the REPEAT INDICATOR will light and blink continuously. The current track will be repeated until it is interrupted.

Repeat All

When the REPEAT BUTTON is pressed twice, the REPEAT INDICATOR will light steadily. The whole disc will be played continuously.

To Cancel the Repeat Function: Press the REPEAT BUTTON until the repeat indicator goes off.

SKIP AND SEARCH MODE

1. During Play or Pause mode, tap the NEXT or BACK BUTTON to go to the next track or go back to the beginning of the current track.
2. During Play mode or Pause mode, press and hold the NEXT/▶▶ or BACK/◀◀ BUTTON to search within the current track with audible high speed playback.

PROGRAM PLAY MODE

This function allows music tracks to be played in a programmed sequence.

Note: Program can only be set in STOP mode.

1. Press the PROGRAM BUTTON once. Both Program Number "01" and the PROGRAM (PROG) INDICATOR will flash.
2. Press the NEXT or BACK BUTTON to select the track to be programmed.
3. Press the PROGRAM BUTTON again to store the selection. The Program Number will advance to "02" and flash to prompt for the next input.
4. You may repeat steps #2 to #3 to program up to 20 tracks. As soon as you have entered the 20th track, the LED DISPLAY will automatically show the programmed tracks one by one in their correct sequence starting from the first. At the end of program review, Program Number "01" and the PROGRAM INDICATOR will both flash.
5. Press the PLAY BUTTON to complete and start program play. Otherwise, press the STOP BUTTON to complete and exit program mode.
6. To review/edit the programmed tracks during play, press the STOP BUTTON and then the PROGRAM BUTTON, the LED DISPLAY will show Program Number "01" and the PROGRAM INDICATOR will both flash. If you do not want to change any track in the program, press PLAY BUTTON or wait about 30 seconds to exit edit mode automatically.
7. To edit a programmed track, first press the PROGRAM BUTTON until you reach the program number whose track you want to change then press the NEXT or BACK BUTTON to select a new track and press PROGRAM BUTTON again to confirm.
8. To cancel program play, press the STOP BUTTON twice while reviewing programmed tracks or open the CD DOOR in STOP mode.
9. To turn off the CD player, slide the FUNCTION SELECTOR to "OFF". The LED DISPLAY and POWER INDICATOR will go off.

AUX IN OPERATION

This CD boombox provides an auxiliary input jack for connecting external audio devices like MP3 players and digital audio devices, and to listen to them through the speakers of this unit. Once the AUX IN jack is plugged in, this unit will switch from CD mode to the AUX mode automatically.

1. Use an audio cable (not included) with one 3.5 mm stereo plug on each end of the cable.
2. Plug one end of the cable into the AUX IN JACK and the other end into the Line-out Jack or Headphone Jack of your external audio device.
3. Turn on both the unit and your external audio device.
4. Set FUNCTION SELECTOR of CD boombox to "CD/AUX".
5. The volume level can now be controlled through the CD boombox. Operate all other functions on the auxiliary device as usual.

Note:

- If you connect this unit to the Line-Out Jack of your external device, you only need to adjust the volume control of the unit. If you connect to the Headphone Jack of your external device, you may need to adjust both the volume controls of your external device and the unit to obtain the desirable volume setting.
- Remember to turn off the unit when you have finished listening. Don't forget to switch off the power of your external audio device as well.
- Remember to disconnect the connection cable from the unit after use in order to be able to listen to CD music again.

CARE AND MAINTENANCE

1. Children should be supervised when using this appliance.
2. Clean your unit with a damp (never wet) cloth. Solvent or detergent should never be used.
3. Avoid leaving your unit in direct sunlight or in hot, humid or dusty places.
4. Keep your unit away from heating appliances and sources of electrical noise such as fluorescent lamps or motors.
5. If drop-outs or interruptions occur in the music during CD play, or if the CD fails to play at all, its bottom surface may require cleaning. Before playing, wipe the disc from the center outwards with a good soft cleaning cloth.



TROUBLESHOOTING GUIDE

If you experience difficulties in the use of this music system please check the following or call 1-800-777- 5331 for Customer Service

Symptom	Possible Cause	Solution
Noise or sound distorted on AM or FM broadcast	<ul style="list-style-type: none"> - Station not tuned properly for AM or FM. - FM: FM telescopic antenna is not sufficiently extended. - AM: The bar antenna is not positioned correctly 	<ul style="list-style-type: none"> - Retune the AM or FM broadcast station. - FM: Fully extend the FM telescopic antenna. - AM: Reposition the unit until the best reception is obtained.

AM or FM no sound	- Unit not in "RADIO" function mode. - Volume set at minimum	- Slide Function Switch to "RADIO" position. - Increase Volume.
CD player will not play	- Unit not in CD function mode. - CD is not loaded properly. - If the CD is self-compiled, the media used may not be compatible with the player. - Exhausted battery	- Select CD function mode. - Load CD with label side up. - Use better quality blank media and retest. - Replace all old batteries.
CD skips while playing	- Disc is dirty or scratched.	- Wipe CD with clean cloth or use another disc.
Intermittent sound from CD player	- Dirty or defective disc - Dirty pick up lens - Player is subject to excessive shock or vibration	- Clean or replace the defective disc. - Use a CD lens cleaning disc to clean the lens. - Relocate the player away from shock or vibration.
Sound appears distorted at high volume setting	- Volume control is set to maximum. - Batteries become low	- Adjust Volume Control to a lower comfortable level. - Replace all the old batteries with new ones.

**90 DAY LIMITED WARRANTY AND SERVICE
VALID IN THE U.S.A. ONLY**

SPECTRA MERCHANDISING INTERNATIONAL, INC. warrants this unit to be free from defective materials or factory workmanship for a period of 90 days from the date of original customer purchase and provided the product is utilized within the U.S.A. This warranty is not assignable or transferable. Our obligation under this warranty is the repair or replacement of the defective unit or any part thereof, except batteries, when it is returned to the SPECTRA Service Department, accompanied by proof of the date of original consumer purchase, such as a duplicate copy of a sales receipt.

You must pay all shipping charges required to ship the product to SPECTRA for warranty service. If the product is repaired or replaced under warranty, the return charges will be at SPECTRA's expense. There are no other express warranties other than those stated herein.

This warranty is valid only in accordance with the conditions set forth below:

1. The warranty applies to the SPECTRA product only while:
 - a. It remains in the possession of the original purchaser and proof of purchase is demonstrated.
 - b. It has not been subjected to accident, misuse, abuse, improper service, usage outside the descriptions and warnings covered within the user manual or non-SPECTRA approved modifications.
 - c. Claims are made within the warranty period.
2. This warranty does not cover damage or equipment failure caused by electrical wiring not in compliance with electrical codes or SPECTRA user manual specifications, or failure to provide reasonable care and necessary maintenance as outlined in the user manual.
3. Warranty of all SPECTRA products applies to residential use only and is void when products are used in a nonresidential environment or installed outside the United States.

This warranty gives you specific legal rights, and you may also have other rights which vary from state to state. TO OBTAIN SERVICE please remove all batteries (if any) and pack the unit carefully and send it freight prepaid to SPECTRA at the address shown below. IF THE UNIT IS RETURNED WITHIN THE WARRANTY PERIOD shown above, please include a proof of purchase (dated cash register receipt) so that we may establish your eligibility for warranty service and repair of the unit without cost. Also include a note with a description explaining how the unit is defective. A customer service representative may need

to contact you regarding the status of your repair, so please include your name, address, phone number and email address to expedite the process.

IF THE UNIT IS OUTSIDE THE WARRANTY PERIOD, please include a check for **\$20.00** to cover the cost of repair, handling and return postage. All out of warranty returns must be sent prepaid.

It is recommended that you contact SPECTRA first at 1-800-777-5331 or by email at custserv@spectraintl.com for updated information on the unit requiring service. In some cases the model you have may be discontinued, and SPECTRA reserves the right to offer alternative options for repair or replacement.

SPECTRA MERCHANDISING INTERNATIONAL, INC.
4230 North Normandy Avenue,
Chicago, IL 60634, USA.
1-800-777-5331

To register your product, visit the link below to enter your information.
<http://www.spectraintl.com/wform.htm>

Licensed by:
Marino Andriani, LLC
Distributed by:
Spectra Merchandising International, Inc.
4230 North Normandy Avenue
Chicago, IL 60634, USA
www.spectraintl.com



HELLO KITTY[®]
by *Sanrio*[®]

©1976, 2013 SANRIO CO., LTD.
Used Under License.
www.sanrio.com



SIL- 34037

0713

Printed in China